

**Rubber Protective Skirting**

**Fork Tine Pockets**

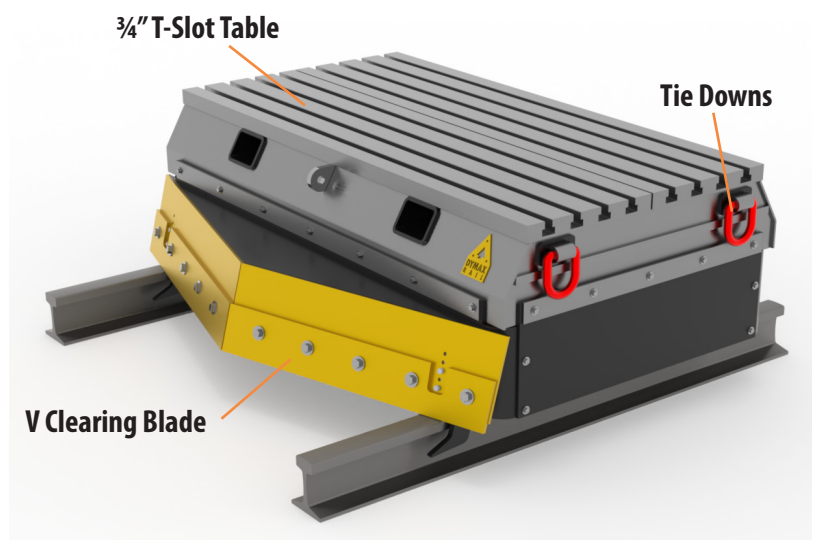

**3/4" T-Slot Table**

**Tie Downs**

**V Clearing Blade**

## BLAST BOOTH DOLLY CART

**RUGGED, HIGH-CAPACITY SOLUTION FOR INDUSTRIAL APPLICATIONS**

The Blast Booth Dolly Cart is a heavy-duty, rail-mounted cart designed for use in industrial blast booth environments. Engineered to withstand demanding applications, this dolly offers superior stability, maneuverability, and efficiency for transporting heavy equipment and materials within manufacturing or maintenance facilities.

### Key Features and Benefits:

- **3/4" T-Slot Table:** Provides a secure and versatile surface for mounting various fixtures and components.
- **V Clearing Blade:** Designed for effective rail clearing in floor applications, ensuring smooth operation and alignment on embedded rail systems.
- **Rubber Protective Skirting:** Protects components from abrasive materials and enhances durability during blasting processes.
- **Tie-Down Locations:** Secure points for safely anchoring loads during transport, preventing unwanted movement.
- **Forklift Pockets:** Integrated forklift pockets for easy handling and repositioning within facilities.

Group No	Model	Weight (lbs)
8265D1	DX-RC-DLBB-56x75-DMX-60TC	3,680
Rail Cart - Track Dolly Blast Booth - 56 inches x 75 inches DymaxRail - 60 ton capacity		
Design and specifications subject to change without notice. Contact DymaxRail for custom solutions.		