



**BUILT TO LAST.**



## **RAIL RIDER H-W1** HI-RAIL SOLUTION FOR WHEEL EXCAVATOR

### **FIRST OF ITS KIND**

Get on the rails fast with the Dymax Rail Rider H-W1. This hydrostatically driven hi-rail attachment quickly adapts to wheel-type hydraulic excavators. There's no cutting, welding or modifying of any kind, unless you want us to like the other guys do.

# KEY FEATURES

- **Elevated stability** – Heavy duty design lowers the excavator's center of gravity when working on rail.
- **Do more work over side** – Available with rail clamps and optional factory enhanced or 3rd rail stabilizer systems.
- **Enhanced safety features** – For better performance on rail, our safety control group includes slew and boom lockouts, automatic pin locks for road or railing positions and enhanced stabilizer solutions and braking systems.
- **Better control** – Our innovative hydraulic drive system provides full hydrostatic feel and control, so when operators need to slow down they can.
- **Better braking** – Equipped with fail-safe hydraulic disc brakes on both axles.
- **Self-contained directional lighting systems** – Red and white directional lights change automatically.
- **100% detachable** – The Dymax Rail Rider H-W1 attaches to your undercarriage as a hi-rail attachment, making it highly efficient.

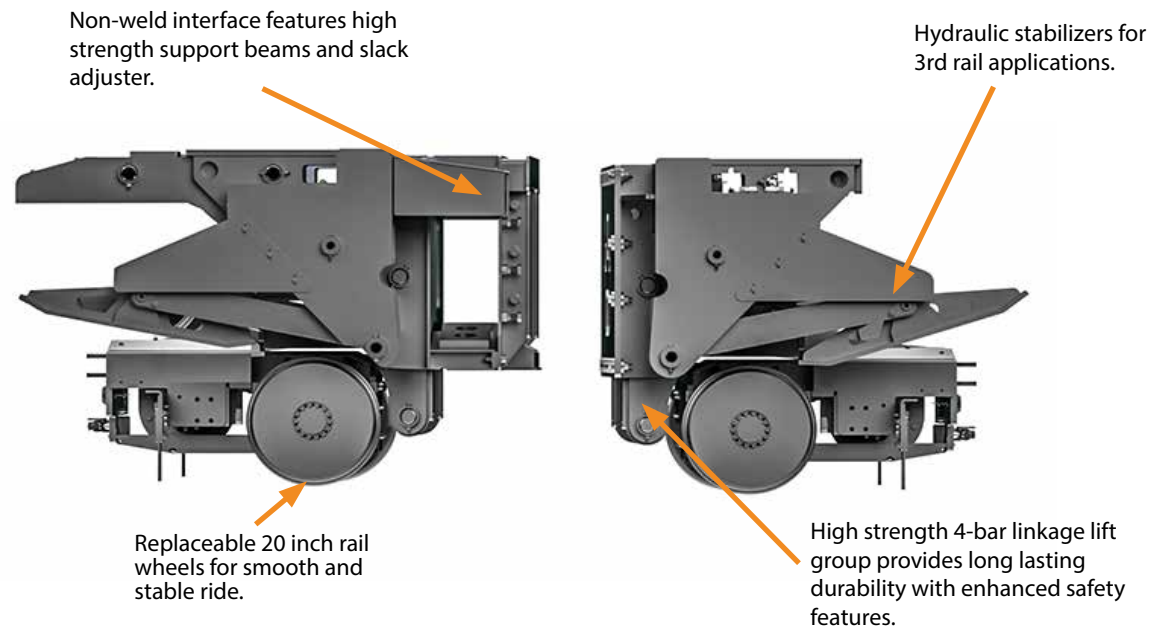

# OPTIONS



- Broad gauge axle design for wide-gauge networks.
- DymaxRail enhanced stabilizer arms for factory mounts.
- 3rd rail stabilizer systems.
- Self-contained air brake circuit for hooking up to air brake trailers.
- Rail clamps.
- Specialized technology systems including slew, height and capacity indicators.

# WORK ATTACHMENTS



TIE HANDLER



TIE CRANE SLIDE GRAPPLE



CRIBBING CLAM BUCKET



BALLAST TAMPER SERIES 14



TRACK MAINTENANCE CARTS

# SPECIFICATIONS



## CATERPILLAR M320 M322

MODEL	STABILIZER TYPE	DESCRIPTION	Weight (lbs) (attachment)
RRDH-W13S-CATM320-HX-20T	3rd Rail - 3S	Rail Rider Hydrostatic-W1 series mount with 3rd rail stabilizers-Caterpillar M320--Hydraulic Excavator-20 ton class	16,000
RRDH-W13S-CATM322-HX-22T	3rd Rail - 3S	Rail Rider Hydrostatic-W1 series mount with 3rd rail stabilizers-Caterpillar M322--Hydraulic Excavator-22 ton class	16,000
RRDH-W13SC-CATM320-HX-20T	3rd Rail - 3S + Clamp	Rail Rider Hydrostatic-W1 series mount with clamps and 3rd rail stabilizers-Caterpillar M320--Hydraulic Excavator-20 ton class	17,000
RRDH-W13SC-CATM322-HX-22T	3rd Rail - 3S + Clamp	Rail Rider Hydrostatic-W1 series mount with clamps and 3rd rail stabilizers-Caterpillar M322--Hydraulic Excavator-22 ton class	17,000
RRDH-W1SC-CATM320-HX-20T	OEM Stabilizer Modified + Clamp	Rail Rider Hydrostatic-W1 series mount with modified OEM stabilizer arm and rail clamps-Caterpillar M320--Hydraulic Excavator-20 ton class	17,500
RRDH-W1SC-CATM322-HX-22T	OEM Stabilizer Modified + Clamp	Rail Rider Hydrostatic-W1 series mount with modified OEM stabilizer arm and rail clamps-Caterpillar M322--Hydraulic Excavator-22 ton class	17,500

Design and specifications are subject to change without notice.

For models not listed, please contact DymaxRail to determine availability. Dymax engineering is always available to custom build hi-rail solutions for your needs.



**DYMAXRAIL** | Toll Free: 800.530.5407 (USA/CAN)  
 402 Miller Drive | Office: +1.785.456.2081  
 Wamego, KS 66547 USA | Fax: +1.785.456.8328

[www.DYMAXRAIL.com](http://www.DYMAXRAIL.com)  
[sales@DYMAXRAIL.com](mailto:sales@DYMAXRAIL.com)

# SPECIFICATIONS



## SENNEBOGEN 718

MODEL	STABILIZER TYPE	DESCRIPTION	Weight (lbs) (attachment)
RRDH-W1SC-SEN718-HX-20T	OEM Stabilizer Modified + Clamp	Rail Rider Hydrostatic-W1 series mount with modified factory stabilizers with rail clamps - Sennebogen 718--Hydraulic Excavator-20 ton class	17,500

Design and specifications are subject to change without notice.

For models not listed, please contact DymaxRail to determine availability. Dymax engineering is always available to custom build hi-rail solutions for your needs.



**DYMAXRAIL** | Toll Free: 800.530.5407 (USA/CAN)  
402 Miller Drive | Office: +1.785.456.2081  
Wamego, KS 66547 USA | Fax: +1.785.456.8328

[www.DYMAXRAIL.com](http://www.DYMAXRAIL.com)  
[sales@DYMAXRAIL.com](mailto:sales@DYMAXRAIL.com)

# SPECIFICATIONS



**VOLVO EW220**

MODEL	STABILIZER TYPE	DESCRIPTION	Weight (lbs) (attachment)
RRDH-W13S-VOEW220-HX-20T	3rd Rail - 3S	Rail Rider Hydrostatic-W1 series mount with 3rd rail stabilizers-Volvo EW220-Hydraulic Excavator-20 ton class	16,000
RRDH-W13SC-VOEW220-HX-20T	3rd Rail - 3S + Clamp	Rail Rider Hydrostatic-W1 series mount with clamps and 3rd rail stabilizers-Volvo EW220-Hydraulic Excavator-20 ton class	17,000
RRDH-W1SC-VOEW220-HX-22T	OEM Stabilizer Modified + Clamp	Rail Rider Hydrostatic-W1 series mount with modified OEM stabilizer arm and rail clamps-Volvo EW220-Hydraulic Excavator-20 ton class	17,500

Design and specifications are subject to change without notice.

For models not listed, please contact DymaxRail to determine availability. Dymax engineering is always available to custom build hi-rail solutions for your needs.



**DYMAXRAIL** | Toll Free: 800.530.5407 (USA/CAN)  
402 Miller Drive | Office: +1.785.456.2081  
Wamego, KS 66547 USA | Fax: +1.785.456.8328

[www.DYMAXRAIL.com](http://www.DYMAXRAIL.com)  
[sales@DYMAXRAIL.com](mailto:sales@DYMAXRAIL.com)



# **DYMAX RAIL**

**402 Miller Drive | PO BOX 297 | Wamego, KS 66547 USA**

**US: 1-800-530-5407 | WORLD WIDE: 785-456-2081**