

MAKE THE BEST CONNECTION

DYMAX RAILCAR COUPLER SYSTEMS

Dymax Railcar Couplers quickly adapt to wheel loaders or tractors, enabling operations such as co-ops, aggregate and load transfer facilities, port and terminal railways and rail yard operators to pull railcars safely.

Key Features and Benefits

- Quickly attaches to your wheel loader or tractor.
- Maximize your fleet investment and use machines you already have.
- All models feature standard pivoting AAR car knuckle with integrated top and bottom retainer plates to provide the best connection in the industry.
- Available for rear tractor applications fitting Category 2, 3 and 4 hitches.
- Available for fitting wheel loaders. Front mounted models can be easily configured with coupler hooks to fit most popular brands.
- Rear mounted wheel loader car couplers are custom engineered to fit the specific machine.

OPTIONAL TRAIN AIR



- Train air solutions enable operators to activate traincar brakes.

THE BEST CONNECTION

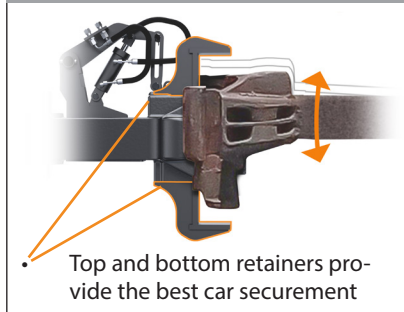

- Top and bottom retainers provide the best car securement

CUSTOM DESIGN SOLUTIONS



- Designed to meet our customers requirements.

MOVE RAILCARS SAFELY. **EASY TO ADAPT.**

TRACTORS - 100HP AND LARGER

BENEFITS

- Quickly attaches to your tractor to enable safe pulling of railcars.

3 POINT MODEL

- Free slide frame with hydraulic pin latch, pivoting knuckle and traincar knuckle retainer stops.

TRACTOR FRONT MOUNT MODEL

- Tractor mounted frame group, pivoting knuckle assembly with hydraulic pin latch and traincar knuckle retainer stops.

OPTIONS

- Train air solution for connecting to train car air brakes.
- Hydraulic positioner available on select models for 3 point applications.



DX-RCQ-HY-RFS-TR
Rear Free Slide Tractor

DX-RCQ-HY-FFX-TR
Front Mount Frame



TRACTOR MODELS

Model	Hookup	Weight (lbs)	
DX-RCQ-HY-RFS-TR Rear 3 point free slide with hydraulic pin and retainer knuckle	Available for Category 2, 3, 4 hitch.	2650	Some models are not listed. To determine what's available for your machine contact Dymax sales 1-800-530-5407. Specifications are subject to change without notice and weights shown are approximate.
DX-RCQ-HY-RHS-TR Rear 3 point hydraulic slide with hydraulic pin and retainer knuckle		2300	

WHEEL LOADERS - ALL SIZES

BENEFITS

- Quickly attaches to your machine to enable safe pulling of railcars.
- Pair with a Dymax snow plow, loader bucket or pallet fork and take care of all your material handling needs.

FRONT & REAR MOUNT MODELS

- Free slide frame with hydraulic pin latch, pivoting knuckle and traincar knuckle retainer stops.
- Rear mounted counterweight type models may require welding and added installation time subject to machine configuration.



DX-RCQ-HY-RFS-WL
Rear Mount Free Slide Frame

DX-RCQ-HY-FFS-WL
Front Mount Free Slide Frame



WHEEL LOADER MODELS

Models	Coupler Type	Weight (lbs)	Caterpillar	Deere	Komatsu	Volvo
DX-RCQ-HY-FFS-WL-40	Front free slide with hydraulic pin and retainer knuckle	3000	924	444-524	WA200	L50-60
DX-RCQ-HY-FFS-WL-50/60		3150	928-930-938	544-624	WA250-320	L70-L120
DX-RCQ-HY-FFS-WL-70/80		3200	950-972	644-824	WA380-470	L150-L180
DX-RCQ-HY-FFS-WL-90		4000	980	844	WA500	L220
DX-RCQ-HY-RFS-WL-50/60	Rear free slide with hydraulic pin and retainer knuckle	3200	928-930-938	444-524	WA200	L50-60
DX-RCQ-HY-RFS-WL-70/80		3200	950-972	544-624	WA250-320	L70-L120
DX-RCQ-HY-RFS-WL-90		3850	980	644-824	WA380-470	L150-L180
DX-RCQ-HY-RFS-WL-100		4500	988K	NA	NA	NA

Specifications are subject to change without notice and weights shown are approximate.



DYMAXRAIL
402 Miller Drive
Wamego, KS 66547 USA

Toll Free: 800.530.5407 (USA/CAN)
Office: +1.785.456.2081
Fax: +1.785.456.8328

www.DYMAXRAIL.com
sales@DYMAXRAIL.com